

Please read the instruction manual before use, and keep it for further reference.

**BEFORE USE, PLEASE PULL THE PAPER TAB FROM THE BATTERY COMPARTMENT (SEE PART E FOR THE PROCEDURE TO GET ACCESS TO THE BATTERY COMPARTMENT).**

**A) DESCRIPTION OF THE SOLAR LANTERN GARDEN**

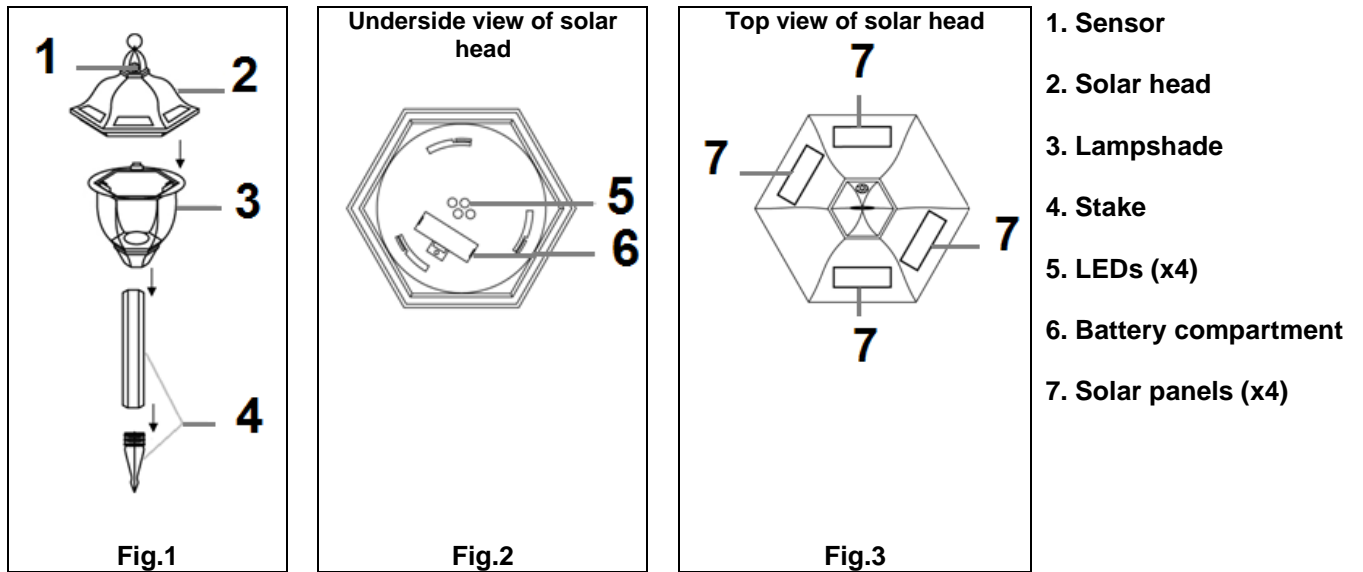

**B) CHOOSING AN IDEAL LOCATION**

Solar light is ideal for lighting gardens and lawns at night. Choose an outdoor location with full, direct sunshine where the solar panel can receive at least 8 hours of sunshine light each day. Please note that if the product is placed in a shady location with little sunlight, it may not charge enough energy, then the lighting time would be shorter at night. The selected location should not be near strong lighting sources such as street lights, which may cause light to turn off automatically.

**NOTE:** The battery has been already charged by the manufacturer. In case the output of light is weak, the electronic level may have probably dropped when you receive it. Please charge it for a full day to get maximum performance.

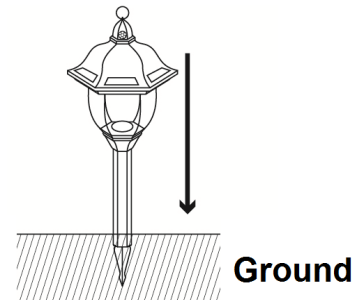

**Charging time about 8-10 hours.**

**C) HOW SOLAR LANTERN GARDEN WORKS?**

The solar lantern garden which has 4 LED bulbs (3 white LEDs + 1 yellow LED) performs 2 lighting functions as follows:

- Nightlight function: The yellow LED turns on at dusk, stays on permanently in the dark and turns off at dawn.

**NOTE:**

- During the day, the solar panels of the lantern convert solar power into the rechargeable battery. At night or when the environment turns to dark, the night light (yellow LED) will turn on automatically releasing the light energy captured during the day.

- The duration of illumination of light depends on your geographical location, weather conditions and seasonal light availability.

- Lighting function: The sensor is automatically activated at dusk. At night, when it detects a movement within about 5 meters, the 3 white LEDs turn on. They turn off automatically about 15-18 seconds after people leave.

**Note:**

If the unit is not functioning, especially after you have handled it, please open it up to check that the batteries are securely fixed in the battery compartment.

## D) TECHNICAL CHARACTERISTICS

<b>Battery pack (rechargeable):</b>	<b>1x rechargeable battery AA NI-MH, 1.2V, 800mA</b>
<b>Battery Pack Charging Time:</b>	<b>8~10 h (Solar energy)</b>
<b>Autonomy:</b>	<b>8 hours</b>
<b>Solar Panel:</b>	<b>Monocrystalline Silicon: 4x0.5V 80mAh</b>
<b>Energy source</b>	<b>Sun</b>

## E) BATTERY REPLACEMENT

In case the light output becomes weaker after a long period of use of the solar lantern, the battery may be beyond its lifespan and needs to be replaced. See below for the procedure:

1. Turn the solar lantern upside down. Then, twist open the lampshade in anti clockwise direction (Fig.4).
2. Under the solar head, remove the cover of battery compartment to replace the old rechargeable battery with a new one (battery specification: 1 x rechargeable AA NI-MH, 1.2V, 800mA). Replace the cover and close.

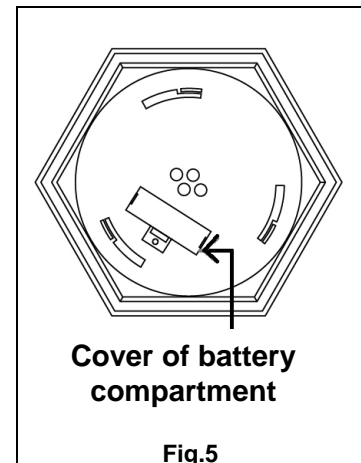
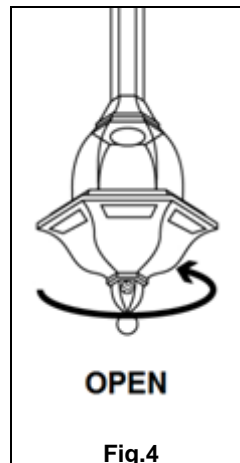

3. In order to close the solar head, position the tenons of the lampshade next to the corresponding rabbets of the solar head (The tenons should be placed next to the holes of the rabbets) (fig.6).
4. Turn the lampshade clockwise until it clicks in place.
5. Then return to upright position.

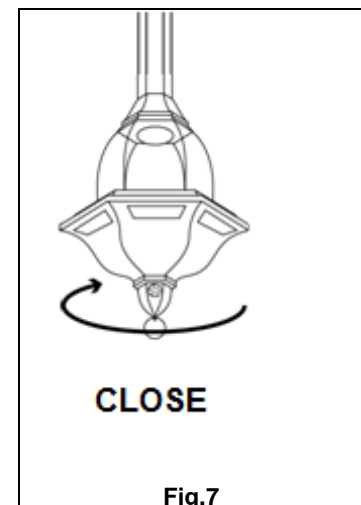
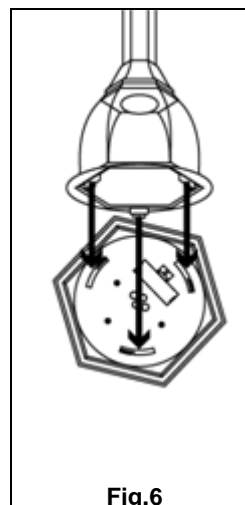

## F) PRECAUTIONS AND MAINTENANCE

- **DO NOT** touch the surface of the solar panel.

- Never try to take apart or repair the top section of the lamp or the solar panels yourself. Take it to a qualified electrician or service person.
- Keep out of reach of children.
- Although the battery has been charged by the manufacturer, the electronic level will have probably dropped when you receive it. Please charge it for a full day to get maximum performance.
- Surface of the solar panels must be kept clean. If it is dusty, it will reduce efficiency of charging. Clean the surfaces of the unit with a soft damp and lint-free cloth regularly to prevent debris from building up.  
**Note: Do not use abrasive or chemical products to clean the solar panels.**
- When not in use, store in a dry cool place.
- You can check the operation of the lights by covering the upper surface of the solar panel completely in order to activate the light sensor.
- In extreme weather conditions such as wind gusts, heavy snowfall, very low temperatures or heavy rains, the unit should be taken indoors to prevent the electrical components from being damaged or some water from seeping into it.

**WARNING: You should not dispose of this device with your household waste. A selective collection system for this type of product is implemented by your local authorities. Please contact your local authorities to find out how and where collection takes place. These restrictions apply because electrical and electronic devices contain dangerous substances that have harmful effects on the environment or on human health and must be recycled.**



**This symbol indicates that electrical and electronic devices are collected selectively. The symbol shows a waste container crossed out with an X symbol.**



**I**

**Marketed by EUROTUPS VERSAND GMBH D-40764 LANGENFELD - Germany**